

Cavity-backed Resistance-loaded Planar Monopole Antenna

Mitsuo TAGUCHI*, **Yoshitaka MATSUOKA**, **Yoichi TOGUCHI****,
Kazumasa TANAKA

Dept. of Electrical & Electronic Eng., Nagasaki University
1-14 Bunkyo-machi, Nagasaki-shi, 852-8521, Japan

** Information Technology Research Center, Omron Corporation
Horikawa-Higashiiru, Shiokoji-dori, Simogyo-ku, Kyoto-shi, 600-8530 Japan

Introduction

An antenna must operate effectively over a wide range of frequencies in many applications such as the impulse radar, which transmit and receive impulse signal. The authors have analyzed the small-sized cavity-backed resistance-loaded monopole antenna and shown its broadband operation for the frequencies from 0.5GHz to 4.5GHz [1]. The dimension of rectangular cavity is 48mm by 44mm by 44mm.

In this paper, this antenna is used for the transmitting antenna of impulse radar, and the actual gain of the antenna with the transmitting circuit is analyzed. In the numerical analysis of antenna, the electromagnetic simulator "Fidelity" based on FDTD method is used [2]. The scattering parameters of transmitting circuit are calculated by using the circuit simulator "S-nap field" [3].

Structure of resistance-loaded monopole antenna and amplifier circuit

Figure 1 shows the structure of cavity-backed resistance-loaded planar monopole antenna. The monopole antenna is located within a rectangular cavity of $C_x = 48\text{mm}$ by $C_y = 44\text{mm}$ by $C_z = 44\text{mm}$ in dimensions. The conducting plate of 30cm by 30cm in size is attached at the aperture of cavity. The resistance R is loaded between the top of monopole and the wall of cavity for reducing ringing within antenna structure. At the feed point of antenna, the amplifier circuit with a silicon transistor 2SC5761 (NESG2030M04) is connected. Figure 2 shows the amplifier circuit.

In the numerical analysis of antenna, the perfectly matched layer of six-layer and fourth-order is used as the absorbing boundary condition. The space steps are from 1 mm to 4 mm (non-uniform mesh). The calculation region is 140mm by 130mm by 136mm in dimensions.

Formulation of gain

Figure 3 shows the equivalent circuit of the active transmitting antenna. The scattering matrix represents the amplifier circuit. V_i^+ and V_i^- are the

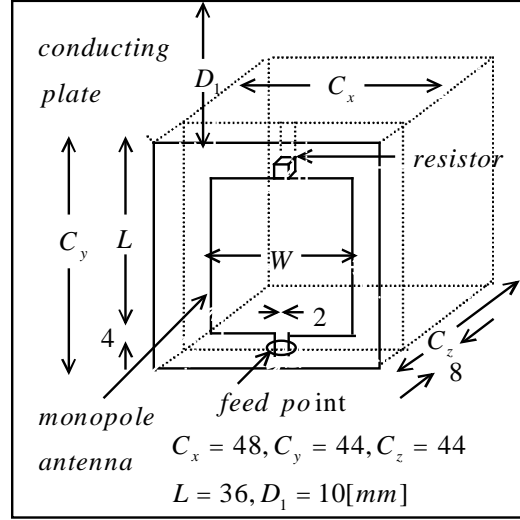

Fig. 1 Cavity-backed resistance-loaded monopole antenna.

incident and reflected voltages at the i -th port ($i=1, 2$). The average power delivered to the antenna is expressed as follows [4].

$$P_L = \frac{|V_2^-|^2}{2Z_0} (1 - |\Gamma_L|^2) \quad (1)$$

V_2^- is expressed in terms of Γ_s and Γ_L .

$$V_2^- = \frac{S_{21}V_1^+}{1 - S_{22}\Gamma_L} = \frac{S_{21}V_{in}}{2(1 - S_{22}\Gamma_L)} \frac{1 - \Gamma_s}{1 - \Gamma_s\Gamma_{in}} \quad (2)$$

where Γ_s and Γ_L are the reflection coefficient seen from the input port of amplifier circuit toward the generator, and that seen from the output port toward the antenna, respectively. Then, the average power delivered to the antenna is expressed as

$$P_L = \frac{|V_{in}|^2 |S_{21}|^2 (1 - |\Gamma_L|^2) |1 - \Gamma_s|^2}{8Z_0 |1 - S_{22}\Gamma_L|^2 |1 - \Gamma_s\Gamma_{in}|^2} \quad (3)$$

Since Z_s is equal to the characteristic impedance Z_0 , Γ_s becomes zero.

Then P_L is reduced as

$$P_L = \frac{|V_{in}|^2 |S_{21}|^2 (1 - |\Gamma_L|^2)}{8Z_0 |1 - S_{22}\Gamma_L|^2} \quad (4)$$

The gain of amplifier circuit G_a is defined as the ratio between the power delivered to the antenna and the input power to the amplifier circuit. Therefore, G_a is summarized as follows.

$$G_a = \frac{|S_{21}|^2 (1 - |\Gamma_L|^2)}{4|1 - S_{22}\Gamma_L|^2} \quad (5)$$

Let G_d be the directivity of antenna element, the actual gain of active antenna is expressed as

$$G = G_a G_d \quad (6)$$

Numerical results

Figure 4 show the calculated input impedance of antenna element and the calculated scattering parameters of amplifier circuit. The width of monopole is $W = 36\text{mm}$ and the loaded resistance is 68Ω . The calculated input impedances agree well with the measured data [1].

Figure 5 show the calculated directivity of antenna element, the power gain of amplifier circuit, and the calculated actual gain of active transmitting antenna. The actual gains more than 10dB are obtained at the frequencies from 0.5GHz to 4.5GHz.

Conclusion

The cavity-backed resistance-loaded planar monopole antenna has been analyzed and its broadband operation has been shown for the frequencies from 0.5GHz to 4.5GHz.

This research was supported in part by Grants-in-Aid for Scientific Research 13650417 from Japan Society for the Promotion of Science.

References

- [1] M. Taguchi, R. Yamane, Y. Toguchi, T. Fujimoto, and K. Tanaka, "Cavity-backed resistance loaded monopole antenna for impulse radar", IEEE AP-S Int. Symp., vol. 2, pp. 656-659, July 2000.
- [2] "Fidelity user's manual, Release 1.2", Zeland software Inc., May 1998.
- [3] "S-nap field for Windows user's manual", MEL Co., May 2000.
- [4] M. Taguchi and T. Fujimoto, "Actual gain of CPW-fed active integrated antennas for television receiver", IEICE Trans. Commun., vol. E81-B, no. 7, pp.1542-1547, July 1998.

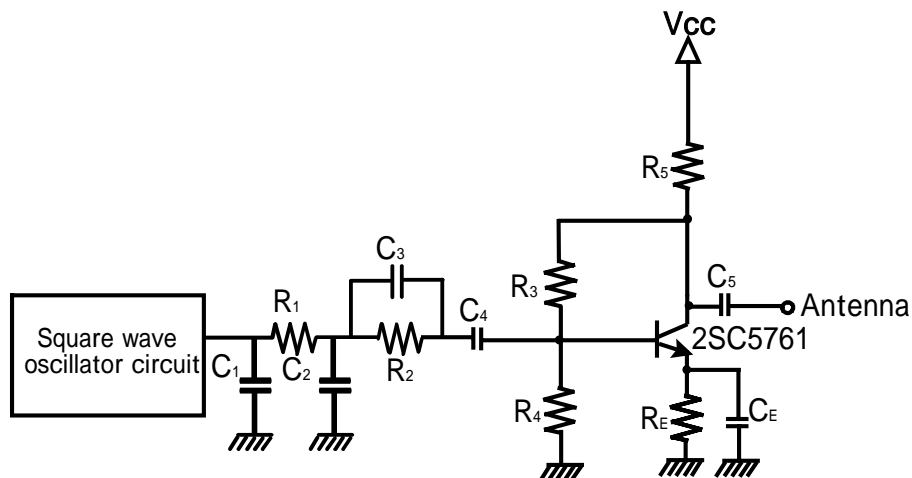

Fig. 2 Amplifier circuit of transmitting antenna

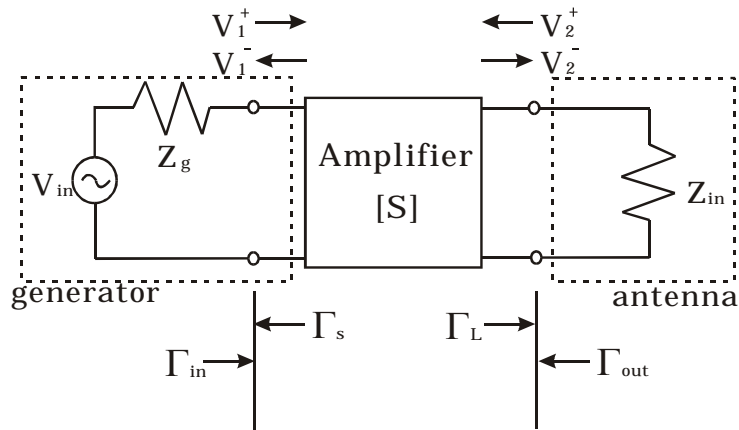

Fig. 3 Equivalent circuit of active transmitting antenna.

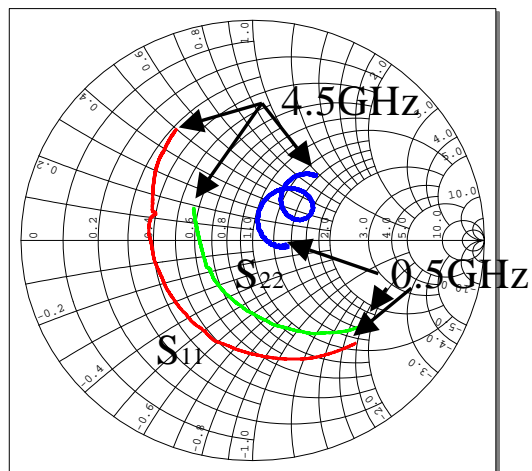

Fig. 4 Calculated input impedance of antenna and scattering parameters of amplifier circuit. $W=36\text{mm}$, Resistance= 68Ω

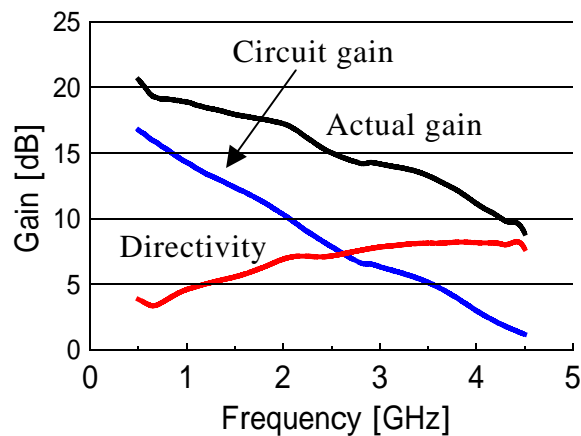

Fig. 5 Calculated directivity of monopole antenna, circuit gain and actual gain of transmitting antenna. $W=36\text{mm}$, Resistance= 68Ω