

Active Inverted-F Antenna on Side of Small Conducting Plate
Mitsuo TAGUCHI* Yoshifumi YANAGISAKO** Kazumasa TANAKA
Dept. of Electrical & Electronic Eng., Nagasaki University
** Graduate School of Science and Technology, Nagasaki University
1-14 Bunkyo-machi, Nagasaki-shi, 852-8521, Japan
E-mail: mtaguchi@net.nagasaki-u.ac.jp

Introduction

The digital terrestrial television broadcasting service will be started this year in Japan. For the antenna of the portable TV, the small sized antenna is desired. The inverted-F antenna is used as the antenna for the mobile communication terminal such as cellular phone due to its small size and ease of design and fabrication [1]. The characteristics of this antenna may be affected by the conducting materials in the vicinity of antenna. Therefore, in the design of such antenna, the existence of surrounding material must be considered.

In this paper, the active inverted-F antenna (AIFA) mounted on side of rectangular conducting plate of 182 mm by 18 mm is numerically and experimentally analyzed at the digital television frequency band. This antenna is fed by the coplanar waveguide (CPW) printed on the conducting plate. The conducting plate is located parallel to the B5-sized conducting plate. The electromagnetic simulator IE3D is used for the analysis of antenna [2].

Analytical model

Figure 1 shows the AIFA mounted on the side of rectangular conducting plate #1 of 182mm by 18mm. This small conducting plate is located parallel to the conducting plate #2 of 182mm by 252mm. The width of antenna element is 2 mm. This antenna is fed by the CPW on the conducting plate #1. The AIFA and CPW are printed on the PCB with the thickness of 1 mm and the relative permittivity of 4.2, and the loss tangent of 0.021. The distance between the inverted-F antenna and the conducting plate #2 is 2 mm. Table 1 shows the antenna parameters. The silicon transistor 2SC3603 is integrated at the feed point. Figure 2 shows the amplifier circuit. In the numerical analysis of inverted-F antenna, the electromagnetic simulator IE3D based on the Method of Moment is used. The calculation frequencies are from 400 MHz to 700 MHz. The cell size is 21.43 mm ($\lambda/20$ at 800 MHz) and the edge cell size is 1% of the cell size. The CPW is not considered in the numerical calculation. Although the infinite PCB is assumed in the numerical analysis, the PCB with size of 182 mm by h+24 mm is used in the test antenna.

Actual gain

The actual gain of active antenna is expressed as follows [3].

$$G = \frac{|V_{oc}|^2}{|V_{oc}^d|^2} \times \frac{|S_{21}|^2 |1 - \Gamma_s|^2}{|S_{21}^d|^2 |1 - \Gamma_s S_{11}|^2}, \quad (1)$$

Where V_{oc} is the open-circuit voltage at the feed point of inverted-F antenna, and Γ_s is the reflection coefficient at the input port of amplifier circuit toward antenna. The superscript d denotes quantities related to the standard half-wave dipole antenna as the reference of gain. $|V_{oc}|^2$ is summarized in terms of the input resistance R_{in} , the radiation pattern $G(\theta, \phi)$ and the incident electric field E_0 as follows [4].

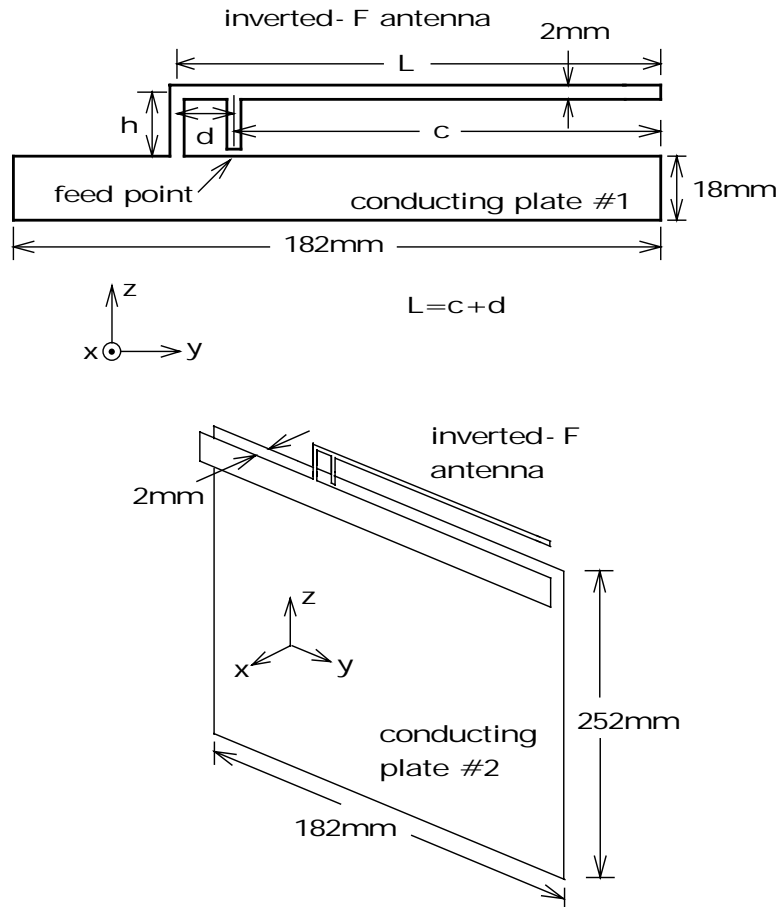

Figure 1 Inverted-F antenna mounted on side of small conducting plate.

$$|V_{oc}|^2 = \frac{4\pi}{k^2\eta} R_{in} G(\theta, \phi) |E_0|^2 \quad (2)$$

Results and discussion

Figure 3 shows the calculated input impedance characteristics. Figure 4 shows the input impedance characteristics of antenna F-3 and the S_{11} parameter of amplifier circuit. Figure 5 shows the return loss of antenna F-3. The discrepancy between the calculate and measured input impedances may be due to the existence of PCB. Since the distance between two conducting plates is 2 mm, the mutual coupling between them may be strong. Therefore the difference of size of conducting plates between the calculation and measurement affects the input impedance characteristics. Figure 6 shows the actual gain of antenna F-3 in the x direction. The actual gains are expressed in values relative to the half-wave dipole antenna. Due to the mismatching between the antenna and amplifier circuit, the measured actual gain becomes lower compared with the calculated results.

Conclusion

The active inverted-F antenna mounted on the side of rectangular conducting plate of 182 mm

by 18 mm has been analyzed numerically and experimentally. The conducting plate is located parallel to the conducting plate of 182 mm by 252 mm. This antenna is promising as the antenna of the digital terrestrial television receiver.

References

- [1] K. Fujimoto, A. Henderson, K. Hirasawa and J. R. James, "Small Antennas", Chapter 2, Research Studies Press Ltd., 1988.
- [2] "IE3D User's manual Release 9", Zeland Software, Inc., March 2002.
- [3] M. Taguchi and T. Fujimoto: "Actual gain of CPW-fed active integrated antennas for television receiver", IEICE Trans. on Communications, E81-B, 7, pp.1542-1547, July 1998.
- [4] M. Taguchi, J. Araki and K. Tanaka: "Small-sized receiving active antenna on rectangular conductor", IEICE Trans. on Communications, J85-B, 9, pp.1572-1574, Sept. 2002 (*in Japanese*).

Table 1 Antenna parameters.

	L (mm)	h (mm)	d (mm)	c (mm)
F-1	120	11	5	115
F-2	120	11	3	117
F-3	115	16	5	110
F-4	115	16	3	112

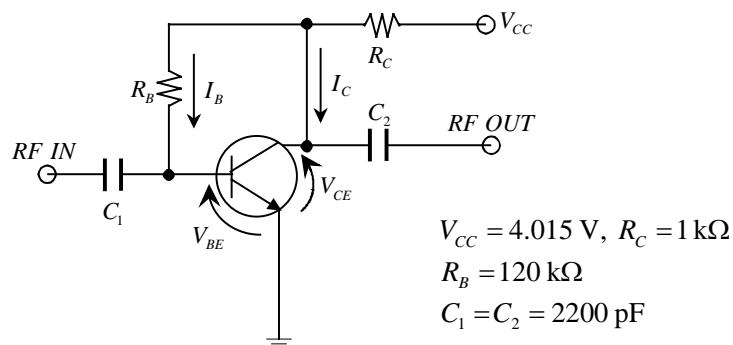

Figure 2 Amplifier circuit.

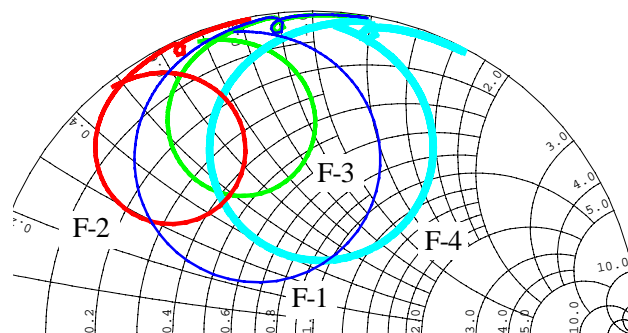

Figure 3 Calculated input impedance characteristics.

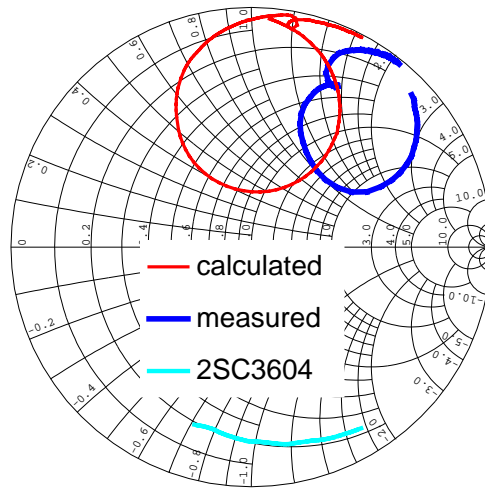

Figure 4 Input impedance of antenna F-3 and S_{11} parameter of amplifier circuit.

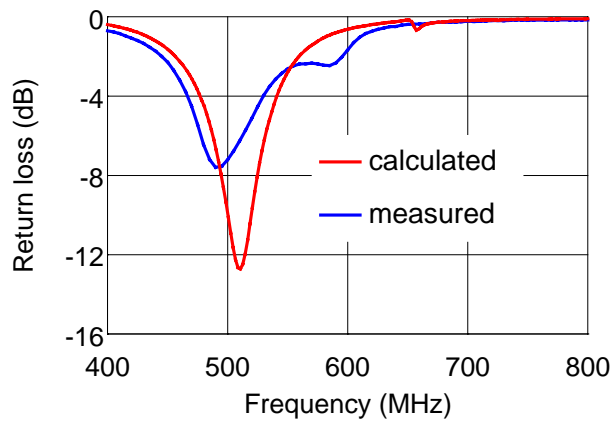

Figure 5 Return loss characteristics of antenna F-3.

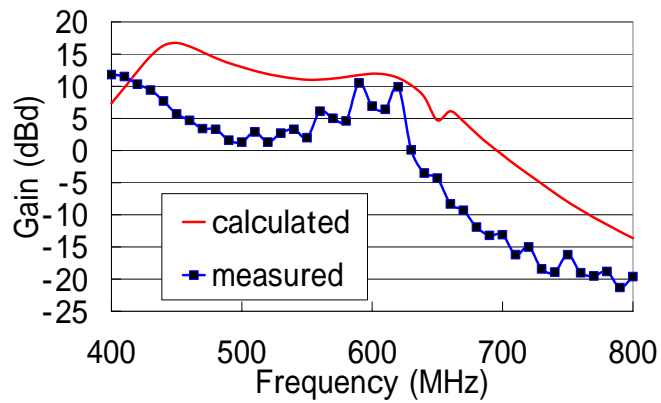

Figure 6 Actual gain of antenna F-3 in x direction.